

A WORD FROM SUZUKI ENGINEERS

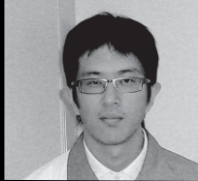

Keiji Sasaki (Product Planning Group)
Improved lower unit gears for DF300AP and DF250AP. Used computer analysis to create a more durable gear and rigid case for Suzuki Selective Rotation System. Better driving performance and reliability than conventional model. Proud flagship outboard.

Masahiro Nanba (Experiment Group)

DF300AP/250AP outboards have advanced Lean Burn and O2 feedback systems for stable and clean emissions. Optimized fuel economy and drivability make them Suzuki's flagship outboard.



Masaya Nishio (Development Design Group)

Improved troll control for DF300AP/250AP by adapting DF90A's system, allowing all engines to be controlled with a single switch. Issues were resolved by analyzing transitions and adding a buzzer control.



Shuichi Sugiyama (Development Design Group)

Suzuki created a Selective Rotation system with improved gear performance and durability. The system replaces old counter-rotation models.

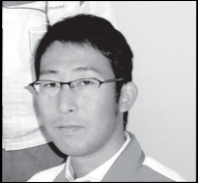

BODY COLOUR

BLACK | WHITE

DIMENSIONS

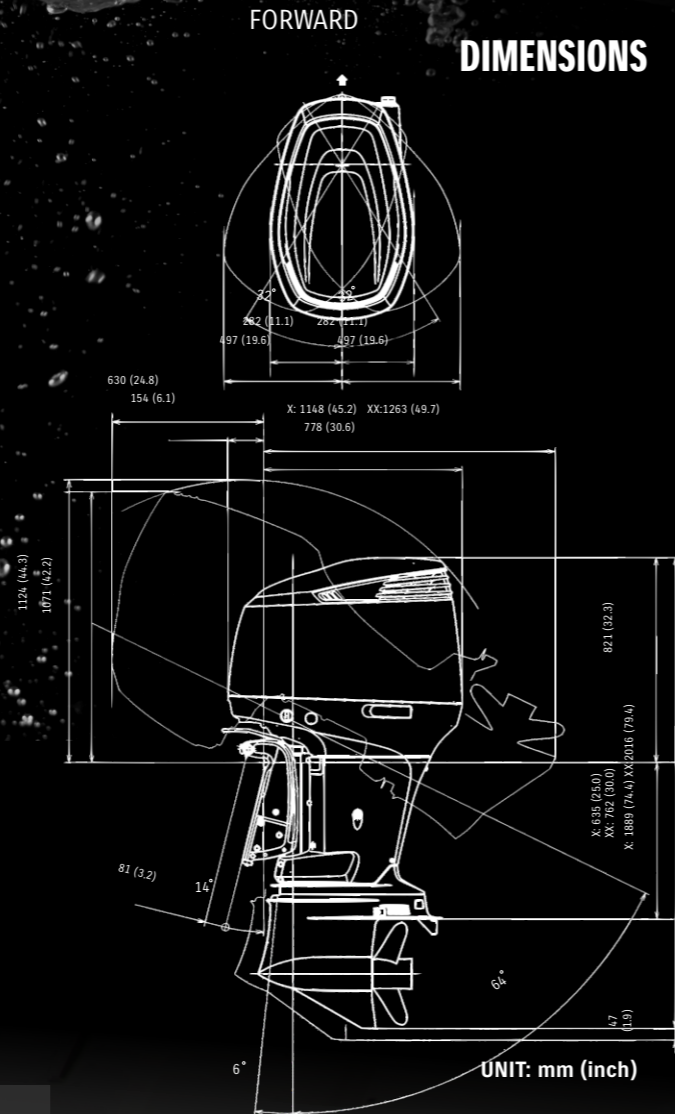

THE
ULTIMATE
OUTBOARD MOTOR



SPECIFICATIONS

	DF300AP	DF250AP
Starting System	Electric	
Recommended Transom Height (mm)	L:508 X: 635 XX: 762	
Weight (kg)	L:284 XL: 290 XX: 299	
Valve Train	DOHC 24-Valve	
Valve Train Drive	Chain	
Displacement (cm ³)	4,018	
Maximum Output (kW)	220.7 183.9	
Bore and Stroke (mm)	98 x 89	
Operation Range (rpm)	5,700 - 6,300 5,500 - 6,100	
Fuel Delivery System	Electrical Fuel Injection	
Oil Pan Capacity (L)	8.0	
Alternator	12V 54 A	
Trim Type	Power Trim and Tilt	
Gear Ratio	2.08;1	
Control System	Drive-By-Wire	
Recommended Fuel	RON91 / AKI87	
Propeller Selection (pitch)	15" - 27.52 (R/R) 17" - 26" (C/R)	

FEATURES



OPTIONAL EXTRA'S



EXCLUSIVE OPTION

FURUNO FishHunter™ Drive



DF300AP / DF250AP

Our V6 outboard engines are designed to deliver exceptional performance, thanks to their advanced technologies. These engines come with a dual overhead cam (DOHC) powerhead, featuring four valves per cylinder and multi-point sequential electronic fuel injection. The 55° V-block design and offset driveshafts make them very compact. Our DF300AP and DF250AP models offer high performance with Variable Valve Timing (VVT) technology that maximizes torque in the low and mid-range

PRECISION ENGINEERED INNOVATION



SUZUKI PRECISION CONTROL (SPC)

Suzuki Precision Control is an advanced computer-based control system that replaces mechanical control cables with electronic wiring for smooth throttle and shift operation. The system offers precise control for single, twin, or triple installation, as well as dual station operation. It also features built-in systems to prevent engine and drive damage, with easy installation thanks to its simple wiring design.

CONTROL PANEL



SWITCH PANEL FOR REGULAR KEY



DRIVE BY WIRE



DURABLE RELIABLE POWERFUL



DUAL WATER INLET

The engine's cooling system uses dual low water intakes on the lower unit to increase water flow and improve cooling efficiency. The forward inlet is positioned at the gear case nose to provide ample water supply at high speeds, while the second inlet is lower for shallow water operation on the DF300AP/250AP.



SELF ADJUSTING TIMING CHAIN

The timing chain in this engine runs in an oil bath, which means it never requires lubrication. Additionally, it comes equipped with an automatic hydraulic tensioner that keeps it properly adjusted at all times. This chain is more durable than belt types in the same class and requires no maintenance.

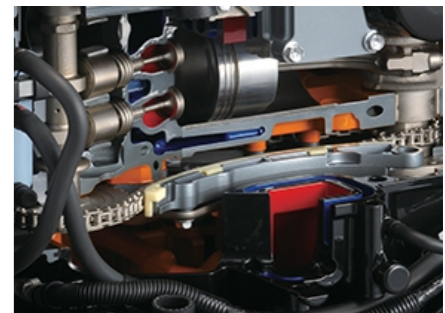

SUZUKI SELECTIVE ROTATION

Suzuki outboard engines come with advanced technology, including Precision Control and Lean Burn Control. They also feature Selective Rotation. In the standard mode, the outboard motor rotates clockwise using the forward gear. But, with a gear-shift change and a counter-rotational propeller, it can operate in counter rotation (anti-clockwise). In counter rotation, the power runs through the reverse gear, which has been altered to match the forward gears. This technology is a world-first for outboard motors.

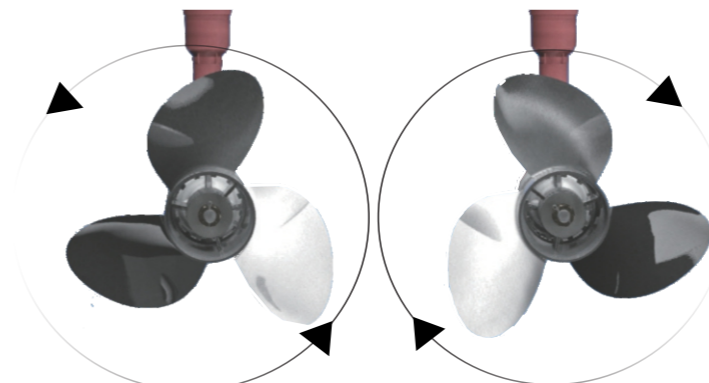

Counter-rotation

Regular-rotation



LEAN BURN CONTROL SYSTEM



LEAN BURN

Suzuki's Lean Burn Control System predicts fuel consumption based on operating conditions, allowing the engine to run more efficiently with a lean air-fuel ratio. When combined with the Suzuki Precision Control electronic throttle and shift system, it offers precise control over engine RPM for improved fuel economy and smooth power transitions. Our in-house testing shows that the DF300AP is 14% more economical than the original DF300A.

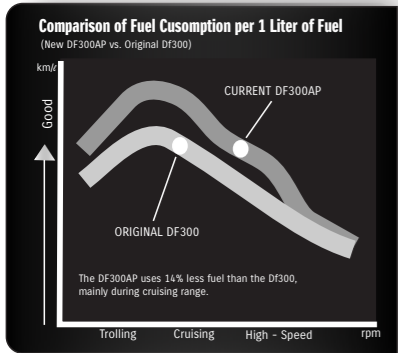

FUEL EFFICIENT

WATER DETECTING SYSTEM



Water in fuel causes poor combustion, reduced power, and corrosion. The DF300AP/250AP Suzuki outboard uses a water detecting fuel filter that warns with visual and audio signals when water is present.



TILT LIMIT



A Tilt Limit System prevents outboard from tilting beyond a certain angle, avoiding damage to the boat or outboard.

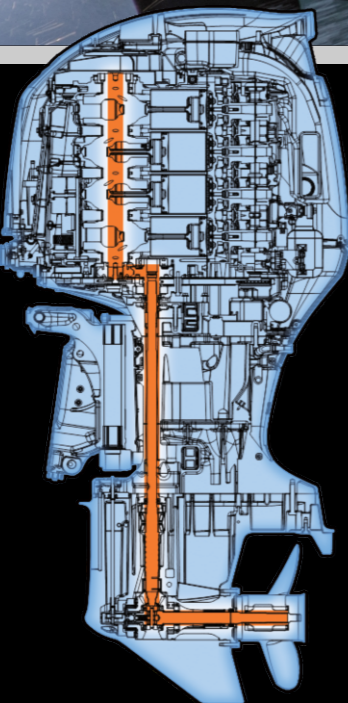

OFFSET DRIVESHAFT

The outboard's center of gravity is moved forward by positioning the engine powerhead closer to the front, resulting in less vibration, more compact size and stable steering performance.

2.08
GEAR RATIO

2 STAGE GEAR RATIO REDUCTION

The Offset Driveshaft system has two stages of reduction, allowing it to turn large propellers with high efficiency, powerful navigation, and quick acceleration.



EASY START SYSTEM

Simply turn the key and release, and the starter stays engaged until the engine starts. This system offers a smoother start of the engine.

OPTIONAL EXTRA'S



TROLL MODE

Suzuki's Troll Mode system provides precise control over engine speed at low rpms for constant trolling. The system uses an independent control switch to adjust revs in 50rpm increments from idle to 1,200rpm. It comes with a convenient control switch and tachometer.



KEYLESS START SYSTEM

Start your car without inserting the key by simply having the key-fob nearby. This system helps deter theft more effectively than a traditional key system.



AUTOMATIC TRIM

The Automatic Trim adjusts the trim angle automatically based on the engine RPM, without the need for manual control. This helps to maintain the trim angle and improve the top speed and fuel efficiency.



SUZUKI DIAGNOSTIC SYSTEM MOBILE PLUS (SDSM+)

SDSM+ is an advanced app for boats attached to SMG4/SMD that provides a unique and satisfying boating experience. It allows you to plan your boat trip, check the condition of your boat and engines, inspect them before departure, and provide engine data to the dealer for maintenance.

INCREASED ALTERNATOR OUTPUT AT LOW SPEED



VARIABLE VALVE TIMING (VVT)

Suzuki's 4.0-liter V6 engine has an aggressive cam profile that delivers maximum output at high rpm. Coupled with Suzuki's advanced Variable Valve Timing (VVT), it offers extra torque for accelerating in the low to mid-range. VVT adjusts the timing of the intake valves and alters intake timing with the camshaft to achieve optimum timing for low and mid-range operation.

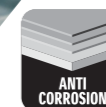
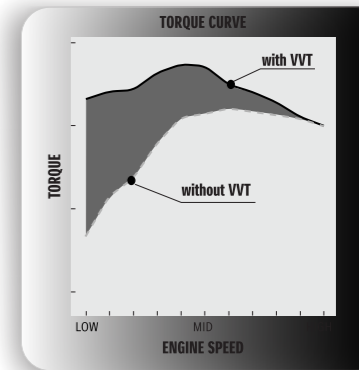

SUZUKI ANTI-CORROSION FINISH

The DF300AP/250AP outboard engine from Suzuki has an anticorrosion finish that increases its durability and protects its aluminum exterior from saltwater damage.

- Resin Clear Topcoat
- Resin Black(or White) Basecoat
- Primer Undercoat
- Suzuki Anti-Corrosion Finish
- Suzuki Aluminium Alloy

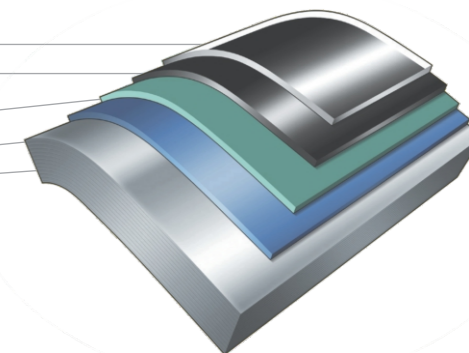

LARGE AIR INTAKE WITH WATER SEPARATOR

The DF300AP/250AP engine has a large air induction port to increase airflow and obtain maximum power output, resulting in more low- to mid-range torque and a wide power band. It also has a water separator and heat shield to protect the electronic throttle body and intake air.

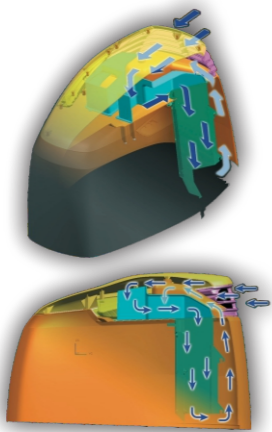

LONG TRACK INTAKE MANIFOLD

The DF300AP/250AP has a tuned long track intake manifold that uses long intake pipes to provide smooth airflow into the engine, enhancing its low-end power.

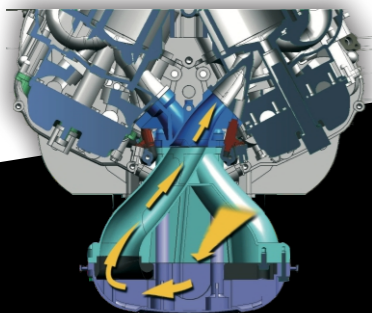

Inceased Alternator Output at Low Speed

Ideal for today's power-hungry fishing boats that spend a lot of time trolling

Applicable Models: All V6 (from '21 model year)

The Increased alternator output at idle and low speed allows for the use of more electric pumps, and equipment

At Idling Speed (650rpm) 23A → 33A **143%**

At 1,000rpm 38A → 43A **113%**

*Except DF200T/DF225T/DF250T

IDLE UP

Increase Idling RPM for battery charging when detected lower battery voltage

FUEL COOLER

Cooler fuel is denser and delivers better performance. To optimize fuel supply and improve combustion, the DF300AP/250AP engines cool the fuel before it enters the engine using a fuel cooler.

SPHERICAL BORE THROTTLE BODY

An 81mm throttle body smooths airflow for better throttle control and stable engine operation at low RPM.

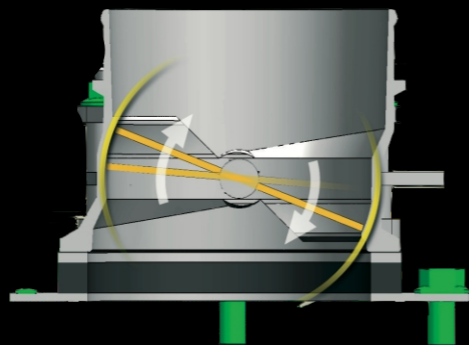

HIGHLY RELIABLE DIRECT IGNITION

The V6 engine uses an advanced ignition system with spark plug caps containing ignition coils. A 32-bit computer controls the system, providing each cylinder with optimal spark timing, while reducing electronic engine noise that can interfere with marine electronics.

WATER COOLED VOLTAGE REGULATOR

The outboard's electric system includes a water-cooled voltage regulator that dissipates heat in the regulator to enhance engine durability.

FUSE BOX

Fuses protecting the DF300AP/250AP's electric system are assembled into a single fuse box located under the cowling on the side front-port of the outboard motor, which provides convenient access while offering a clean exterior.

STRENGTHENED FORGED PISTONS

The V6 engine's pistons have an alumite coating on the upper portion for heat resistance and a resin coating on the skirt for reduced friction and wear.

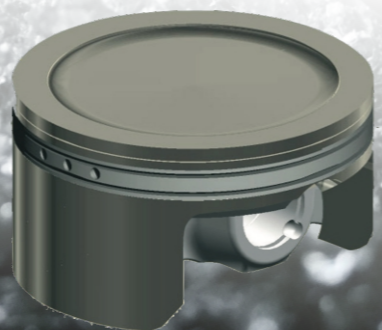

TRIPLE INSTALLATION



DUAL INSTALLATION



SINGLE INSTALLATION



HIGHER TORQUE DURABLE PERFORMANCE

LOWER UNIT

The outboards have redesigned lower units that accommodate the Suzuki Selective Rotation system, which integrates regular and counter-rotation models into one unit. A switch engages counter-rotation mode. The DF300AP/250AP has a 2.08:1 final drive ratio and durable gear designs. It turns a 406mm propeller for optimum performance on any boat. A two-way water inlet enhances cooling efficiency.



SUPERIOR DURABILITY

With the addition of Suzuki Selective Rotation, the gears in the lower unit were redesigned using a different alloy and slightly larger diameters to deliver greater rigidity. The gears are specially heat treated, creating highly durable gears.



LOW DRAG GEAR CASE

The DF300AP/250AP has a new low drag gear case that accommodates the Suzuki Selective Rotation system. The larger case is designed to be more hydrodynamic, resulting in greater efficiency and less drag. The high drag areas are highlighted in red in the illustrations below. The new design allows the lower unit to slice through the water with less drag.

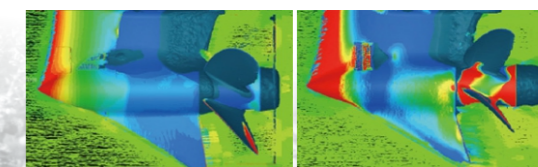

Suzuki's four-stroke technology is highly advanced, ensuring cleaner and more efficient operation that meets the Recreational Craft Directive and has a three-star rating from the California Air Resources Board.